

**C.U.SHAH UNIVERSITY**  
**Winter Examination-2015**

Subject Name: Engineering Graphics & CAD

Subject Code: 4TE02EGC1

Branch: B. Tech. (All)

Semester: 2

Date: 21/11/2015

Time: 10:30 To 1:30

Marks: 70

Instructions:

- (1) Use of Programmable calculator & any other electronic instrument is prohibited.
- (2) Instructions written on main answer book are strictly to be obeyed.
- (3) Draw neat diagrams and figures (if necessary) at right places.
- (4) Assume suitable data if needed.

Q-1

Attempt the following questions:

14

- a) A half-moon protractor is divided into how many degrees? (i) 360 (ii) 180 (iii) 270 (iv) 310.
- b) When lettering a CAD drawing, for clarity you should limit the number of fonts to: (i) one (ii) two (iii) three (iv) any number.
- c) The primary unit of measurement for engineering drawings and design in the mechanical industries is the: (i) Millimeter (ii) Centimeter (iii) Meter (iv) Kilometer.
- d) This is how axonometric, oblique, and perspective sketches show objects:  
(i) Orthographically (ii) Pictorially (iii) Obliquely (iv) Parallel.
- e) This type of projection is when projectors are parallel to each other, but is at an angle other than 90 degrees to the plane of projection: (i) Oblique projection (ii) Perpendicular projection (iii) Aesthetic projection (iv) Angular projection.
- f) The top, front, and bottom views align in this manner: (i) Horizontally (ii) Vertically (iii) According to the planar views (iv) Parallel to the frontal plane.
- g) If a plane is parallel to the plane of projection, it appears: (i) True size (ii) As a line or edge (iii) Foreshortened (iv) As an oblique surface.
- h) This line pattern is composed of three dashes, one long dash on each end with a short dash in the middle: (i) Object (ii) Hidden (iii) Center (iv) Phantom.
- i) This is the plane upon which the top view is projected: (i) Horizontal (ii) Frontal (iii) Profile (iv) Base.
- j) The section view drawing in which one fourth of an object has been marked for removal is known as a..... section. (i) Full (ii) Half (iii) quarter (iv) none of the above.
- k) When filling an area with a hatch pattern in AutoCAD the drafter needs to be able to..... : (i) see the entire bounding area to hatch (ii) set Ortho on (iii) turn ISO grid off (iv) set the layer to Defpoints.
- l) If a designer is developing a plan for a project in which the entire part is made out of  $\frac{3}{4}$ " thick plywood and he only wants to use one view, he should use the ..... view. (i) Front (ii) Top (iii) Right (iv) Back.
- m) This is used to indicate that a surface is to be machined: (i) Finish mark (ii) Machining mark (iii) Roughness indicator (iv) Coordinate mark.



- n) If an object lies in third quadrant, its position with respect to reference planes will be: (i) in front of V.P, above H.P (ii) behind V.P., above H.P. (iii) behind V.P., below H.P. (iv) in front of V.P., below H.P..

Attempt any four questions from Q-2 to Q-8:

Q-2

- a) Construct a plain scale of R.F.= 1:50 to show meters and decimeters and long enough up to 8 meter. Indicate 6.7 m distance on scale. 04
- b) Figure shows an offset slider crank mechanism. Crank OB is 30 mm long and rotates in clockwise direction. Connecting rod AB is 128 mm long. Offset is 40 mm. Draw the loci of two points P and R. PB and BR are 45mm and 30 mm respectively. 05

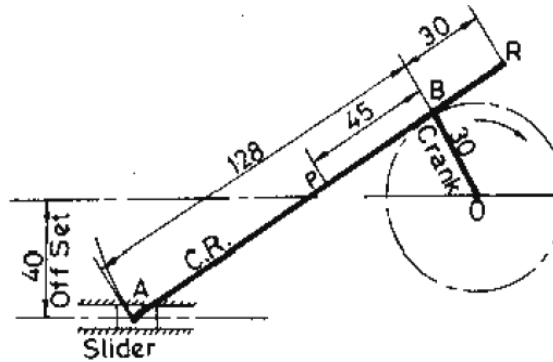

- c) An inelastic string 150 mm long has its one end attached to the circumference of a circular disc of 35 mm diameter. Draw the curve traced out by other end of the string, when it is completely wound round the disc, keeping always tight. Name the curve. 05

Q-3

- a) A line PQ, 65 mm long is parallel to and 40 mm below H.P. Its two ends P and Q are 25 mm and 45 mm behind V.P. respectively. Draw the projection and find the inclination of line with V.P. 07
- b) A regular pentagonal plate of 50mm sides has one of its corners on HP. The plane of the pentagon is inclined at  $30^{\circ}$  to HP. The side of the pentagon which is opposite to the corner, which is on HP, is inclined at  $45^{\circ}$  to the VP. Draw the projections of the plate. 07

Q-4

- a) The front view of a line AB, 90 mm long, measures 65 mm. front view is inclined to XY line by  $45^{\circ}$ . Point A is 20 mm below H.P. and on the V.P. Point B is in third quadrant. Draw the projections and find inclinations of line with H.P. and V.P. 07
- b) A semi circular thin plate of 60 mm diameter, rests on H.P. on its diameter, which is inclined at  $45^{\circ}$  to the V.P. and the surface is inclined at  $30^{\circ}$  to the H.P. Draw the projections of the plate. 07

Q-5

- a) The frustum of a cone, having bottom base diameter 70 mm, top base diameter 30 mm and axis 50 mm, is resting on one of its generators on the H.P. Its T.V. of axis is inclined at  $30^{\circ}$  to the V.P. Draw its projections. 07
- b) Figure shows the elevation of cut Hexagonal Prism, cut by curved and flat cutting planes. Draw the complete development of the prism. 07



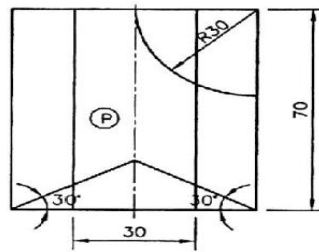

- Q-6 a) A pentagonal pyramid, side of base 40 mm and height 75 mm, is resting on H.P. 07  
 on one of its edges of base with axis parallel to V.P. and inclined to H.P. by  $60^\circ$ .  
 It is cut by a horizontal section plane passing through the highest corner of the  
 base. Draw elevation and sectional plan of the pyramid.
- b) Explain with illustration following commands. i) Donut ii) Spline iii) Offset iv) 07  
 Multiline v) Zoom vi) Break & Trim vii) Array.
- Q-7 a) Draw front view and top view and left hand side view of the object shown in 07  
 Fig.-1 according to first angle projection method.

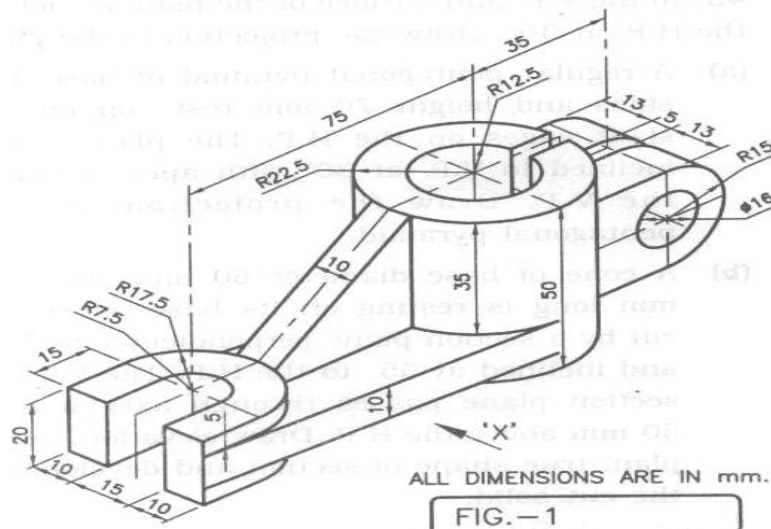

- b) Draw the isometric view of the object, the orthographic views of which are 07  
 shown in the figure below.

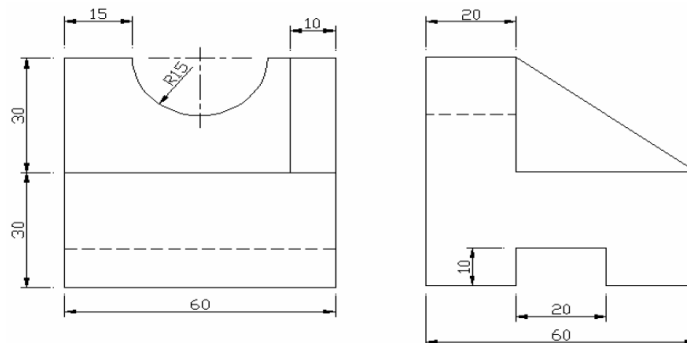

Q-8

- a) Following figure shows the pictorial view of the object .Draw the sectional Front view , Top view and and left hand side view using first angle method of projection.

07

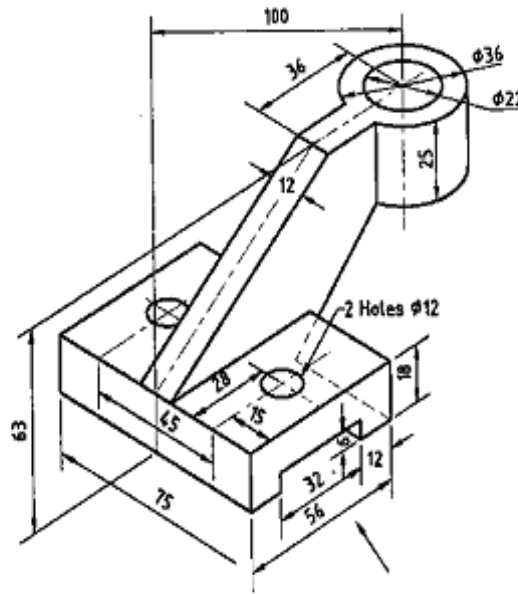

- b) Draw the isometric view of the object, the orthographic views of which are shown in the figure below.

07

